



A Thermax Group Company

RIFOX - Hans Richter GmbH Spezialarmaturen



Special Features are our Strength

**Your Specialist Concerning
Condensate Technology, Drain and Vent Valves**

Our Vision: To Inspire our Customers

RIFOX – Hans Richter GmbH Spezialarmaturen was established by Hans E. Richter in February 1949.

For over 60 years we master the world markets challenges and are among the leading specialists for condensate technology. We are especially well known for developing float-controlled steam traps and vent valves for highest pressure stages and temperatures from -196°C up to 550°C .

From 2009 until 2012 our production site in Bremen belonged to the worldwide operating VIRGO Group. Since April 2012 RIFOX is part of the stock-listed Thermax Group.

At present RIFOX in Bremen has 35 employees. The European quality standards our products are granted by a comprehensive quality management system for our in-house production. According to the requirements we engineer and produce high standard serial products and customized special designs. Our sales portal www.rifoxglobal.de offers a variety of standardized valves from our stock - this grants our customers short delivery times.



Our Services:

RIFOX products are developed according our philosophy „Install and forget“, enabled by the following:

- Individual product development
- Certification according to DIN EN ISO 9001; 2012 and performance and classification of our products according to Pressure Equipment Directive PED 97/23/EC; KTA 1401
- Microprocessor-based leakage testing facility to monitor the production quality of RIFOX valves
- In-house CNC-manufacturing, turnery, welding, assembly, testing and painting
- The unique Rotary-Slide-Valve Control Unit, developed to discharge condensate out of steam and compressed air systems and cold gases out of liquid pressure systems

Our extensive product range includes:

- Steam Traps
- Level Controller
- Pumps & Pump Stations
- Drain Valves
- Vent Valves
- Sight Glasses
- Strainers
- Non-Return Valves
- Dryer
- and many more

RIFOX Rotary-Slide-Valve Control

The purpose of Steam Traps is to discharge condensate and liquid out of steam and gas systems and to avoid steam and gas loss. For smooth operation choosing the right trap and its proper installation is extremely important. Our experienced RIFOX team is pleased to help finding the best-fitting solution for your application.

Convince yourself of the unique RIFOX Rotary-Slide Technique:

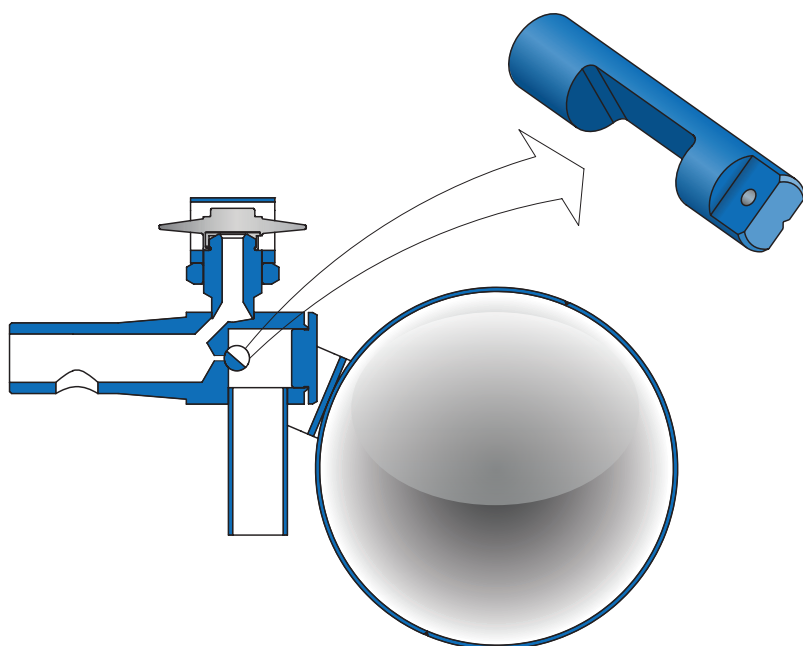

Advantages:

- only one moving point
- regulation device together with shut-off device
- exact, impact-free and silent condensate discharge
- independent of changes in temperature and pressure
- no whirlpool effect, consequently no loss of steam
- insensitive to contamination
- extremely long-lasting, little wear
- extremely low maintenance
- simple system, few parts

Our Know-how is our Strength

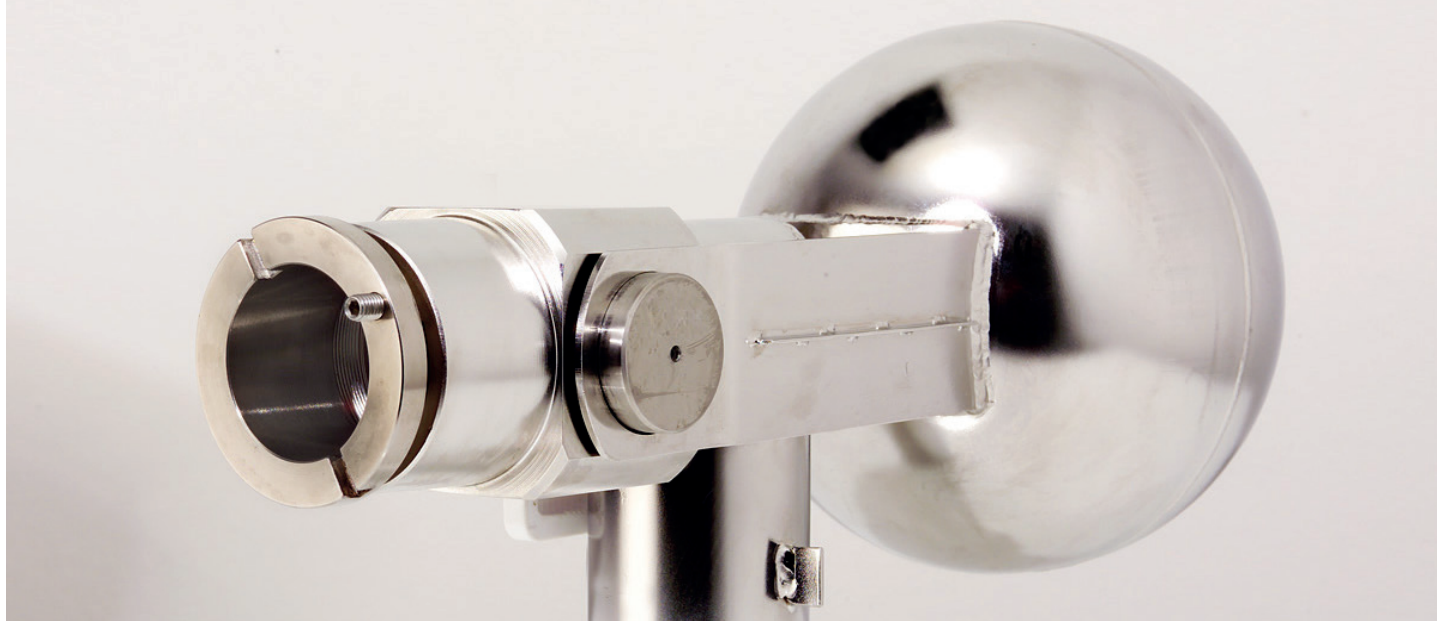

RIFomat

Float-Controlled Steam Trap

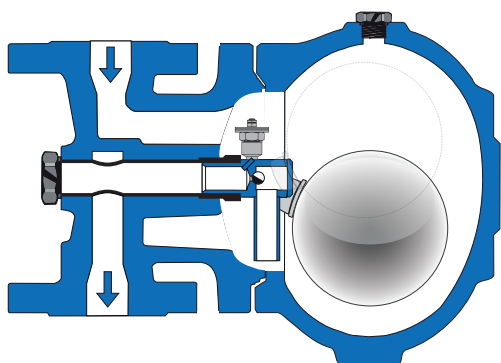

Application

- Draining steam, gas and fluid spaces
- Ideal for draining pipes

Function

- Increasing level opens and decreasing level closes the outlet without delay, independent of pressure and temperature fluctuations

Special characteristics

- The rotary slide valve is both swivel joint and shut-off device
- Proportional control behaviour
- Fast-reacting for hot and cold media

Venting

- Operating at steam requires additional venting device:
 - Manually via control screw
 - Vent jet
 - Thermal venting device

Additional equipment:

- Drain plug
- Reflective water level sight glass
- Non return valve
- Check valve
- Different thermal venting devices

Application examples

- Draining compressed air and pressurized gas systems, heat exchangers and steam distributors
- Draining main lines

Possible Installation of Vario

Vario-SO

- Installation in vertical pipes
- Flow direction from top to bottom

Vario-SU

- Installation in vertical pipes
- Flow direction from bottom to top

Vario-WR

- Installation in horizontal pipes
- Flow direction from right to left

Vario-WL

- Installation in horizontal pipes
- Flow direction from left to right

RIFObi

Bi-Metallic Steam Trap

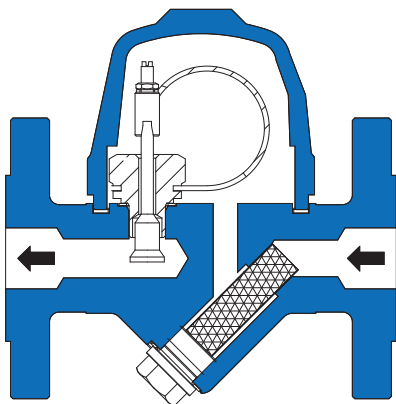

Application

- Draining heat tracings
- Draining special pipes

Function

- Increasing temperature closes, decreasing temperature opens the valve

Design Features

- Robust and insensitive to water hammers, frost and over-heating
- Depending on the media temperature continuously or intermittently condensate discharge
- Adjustable under cooling even at low pressure differences
- Valve also acts as return flow lock

Venting

- Automatic start-up and continuous bleeding when using as a steam trap

Application examples

- Steam condensate with under cooling
- Heat tracings on product tubes, process chambers etc.
- Ideal for draining steam spaces

RIFOkä

Thermo-Controlled Capsule Trap

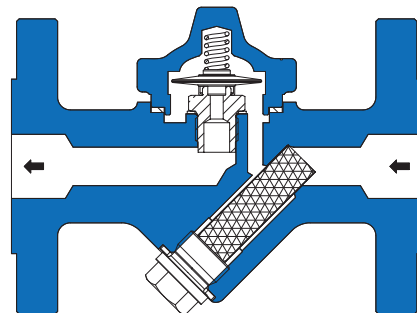

Application

- Draining pipes
- Draining heat tracings

Function

- A special liquid inside the capsule evaporates and condenses due to changes in temperature

- Rising temperature closes, decreasing temperature opens the outlet

Design features

- Depending on the capsule type lower or stronger condensate under cooling
- Lower under cooling prevents from condensate back-up

Venting

- Automatic start-up and continuous venting when used as trap

Additional equipment

- Non return valve
- Steam lock release nozzle

Application examples

- Draining pipes, heat tracings, steam distributors and smaller heat consumers
- Ideal for venting pipe systems
- Ideal for venting steam chambers

RIFOdyn Thermo- Thermodynamic Steam Trap

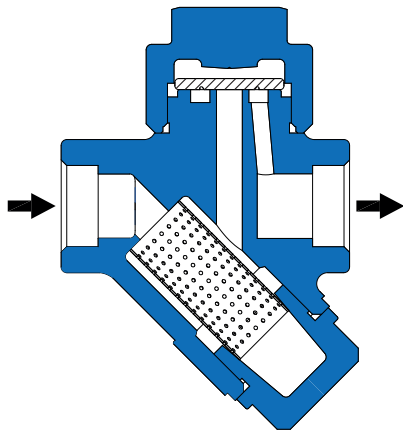

Application

- Draining compressed air and pressurized gas systems
- Steam spaces without rock bottom for draining

Function

- Thermodynamic steam traps are draining steam condensate intermittently by using thermal and fluidic properties

Design Features

- Small and compact
- Adjusts itself to the operating conditions
- Discharged condensate has very small under cooling
- Robust valve design
- insensitive to water hammers and frost
- Design gasket free, metal-seated
- Valve also acts as return flow lock

Application examples

- Draining vulcanizing machines
- Rotary cylinders
- Heat tracings
- Steam pipes
- Draining boilers, finned tubes and laundry machines

RIFOjet Jet Steam Trap

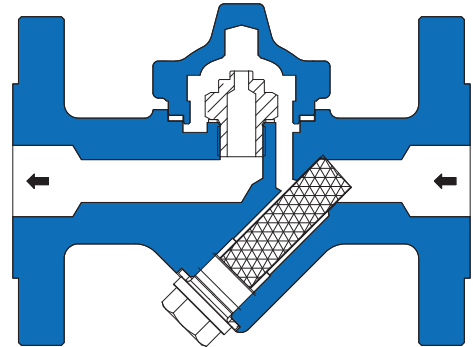

Application

- Multi-stage pressure systems
- Condensate systems with no draining rock bottom

Function

- Pressure drops over the nozzle length cause flash steam and a necking of the outlet
- At no-load operating an enlargement of the steam capacity causes the necking

Design Features

- Low wear and trouble-free
- Insensitive to dirt
- Automatic condensate discharge when system is switched off
- Variable mounting positions

Venting

- Ideal for venting steam spaces
- Automatic start-up and continuous bleeding when using as a steam trap

Application examples

- Draining turbines during start-up
- Draining boilers, finned tubes, rotary cylinders and laundry machines

RIF0level

Level-Control

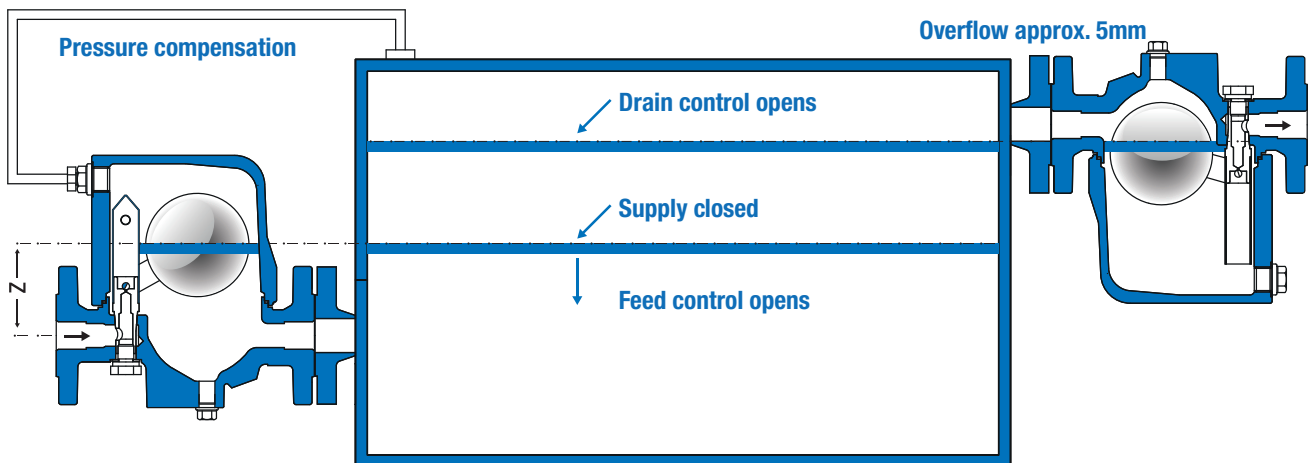

Application

- Secure the fluid level
- Drain control: limit the maximum fluid level
- Feed control: secure the minimum fluid level

Function

- Drain control: rising level opens; falling level closes the outlet without delay
- Feed control: rising level closes; falling level opens the outlet without delay
- Independent from pressure and temperature changes

Assessment / Summary

- Compact and dirt resistant
- Reliable and long lasting
- The rotary slide valve is both, swivel joint and shut-off device

Installation

- Drain and feed control: horizontal
- Feed control with compensation line (balance line)

Purpose

- Filling level control
- Fluid level control
- Water supply, tank systems

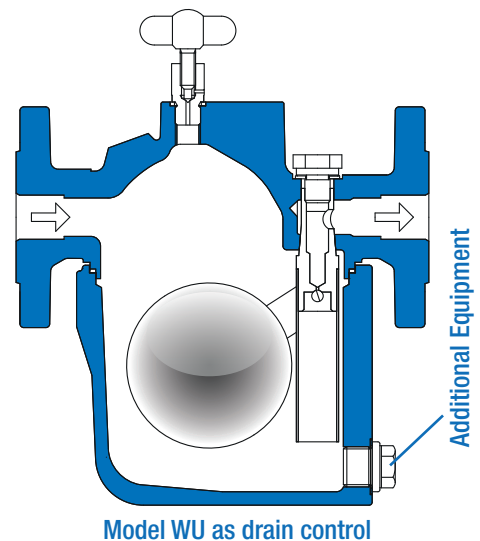

Model WU as drain control

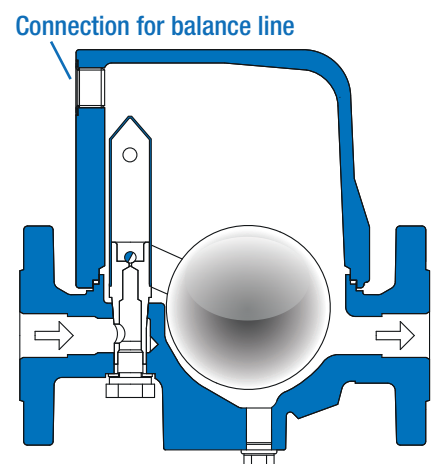

Model WU as feed control

RIFOdry

Fine Dryer & Fine Filter

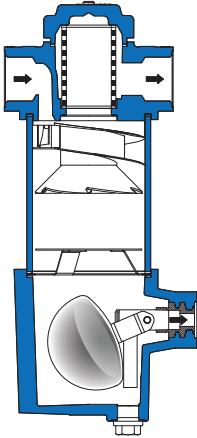

Application

- Drying compressed air, gas and steam with a moisture efficiency up to 98%

Function

- Self-regulating centrifuge nozzle
- Fine filter filters fine dirt & floating particles
- Drop-shaped moisture will be discharged completely and under pressure directed to the outside

Design Features

- Automatic adjustment to pressure and capacity changes

Additional Equipment

- Blow down valve instead of drain plug
- Pressoquick additional draining
- Stainless steel fabric-screens with brass perforated plate shell

Application Examples

- Behind compressors
- Before end users

RIFOair

Vent Valve

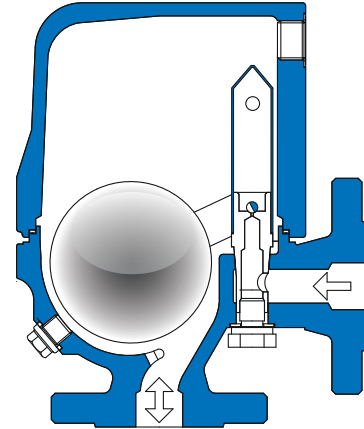

Application

- Venting fluid spaces

Function

- Rotary slide valve drains air and gases out of the fluid spaces
- Outlet is closed when float is down
- Increasing level opens the outlet

Design Features

- Continuously venting without delay
- Insensitive to back pressure
- Pressure changes do not affect the function
- High discharge capacity

Additional equipment

- Gaskets free of non-ferrous metal
- Hosing screws made of A4-70
- Control unit with special cross section

Application examples

- Fluid vessels
- Pipes
- Heating surfaces

RIFOplus Strainers

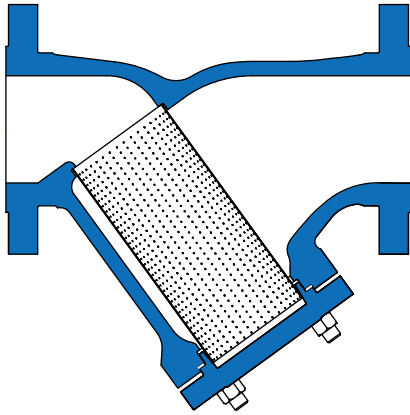

Application

- separate from dirt particles
- cleaning the operating media

Function

- Medium flows through the strainer from the inside to the outside
- dirt and small particles get trapped inside the strainer instead of inside the housing

Application features

- low maintenance
- robust and simple design
- easy cleaning

Additional equipment

- inside strainer made of different materials and with different mesh sizes
- Flanges according to ANSI B 16.5
- Butt weld ends

Application examples

- Before dirt-sensitive valves like control valves

RIFOplus Non Return Valve

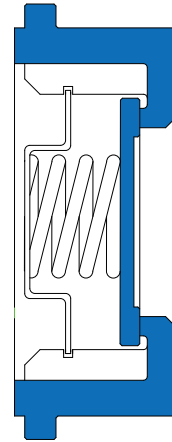

Application

- Prevent from back flow into condensate and fluid systems

Function

- Valve plate is lifted out of the seat when flowing through
- When flowing the other direction plate is pressed into the seat to prevent the media from flowing back

Design Features

- Installation length according DIN
- Installation between flanges

Additional Equipment

- Elastic gaskets
- Special springs between 20 and 500 mbar opening pressure
- Special materials on request
- Holding flanges for the use as vent valve or vacuum breaker
- Special Design for swinging systems (piston compressors)

Application examples

- Before and behind steam traps
- Behind valves and systems
- Usable as vent valve, vacuum breaker and suction valve

RIFOlux

Sight Glasses

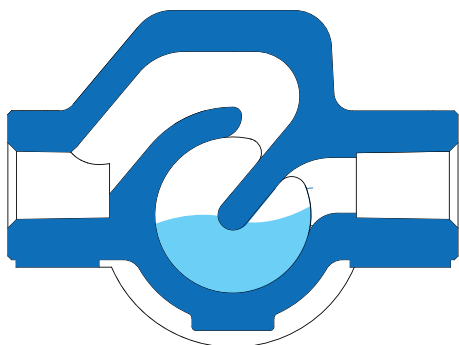

Application

- Checking the level and flow inside pipes
- Checking the function of steam traps

Function

- Sight glass to be installed before the steam trap
- Flow direction is visible when looking at the drop lip

Design Features

- Reliable checking of function and performance of systems and valves, especially proportional working steam traps

Application examples

- Pipe systems
- Condensate systems

RIFOplus

Ultrasonic Measuring Instrument



Application

- Mobile Measuring Instrument to check the performance of traps
- Monitor the proper function of traps and estimate occurring steam losses

Function

- Inspection by using the emitted ultrasonic level of traps
- Measurement of temperature integrated

Design Features

- User-friendly application, easy and fast handling
- The reliable results grant plants security and prevent from condensate losses
- Built-in speaker for ultrasound
- Digital and graphic display
- Auto Power-off

Additional Equipment

- Integrated memory for test values
- Data transfer to PC
- Headphone with excellent sound insulation
- Extension for temperature sensor

Application examples

- Judging traps and other valves in steamed plants

RIFOplus Condensate Compensators

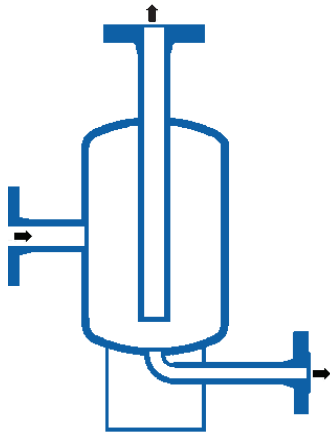

Application

- To prevent pipes, valves and plants from damages due to water hammer

Function

- In the upper housing part there is an air and steam cushion that compensates condensate hammers
- Reduces pressure strokes inside the collection pipe

Design features

- No moving parts
- Robust and maintenance-free

Application examples

- Steam plants
- Valves
- Pipe systems

RIFOlift Condensate Pump

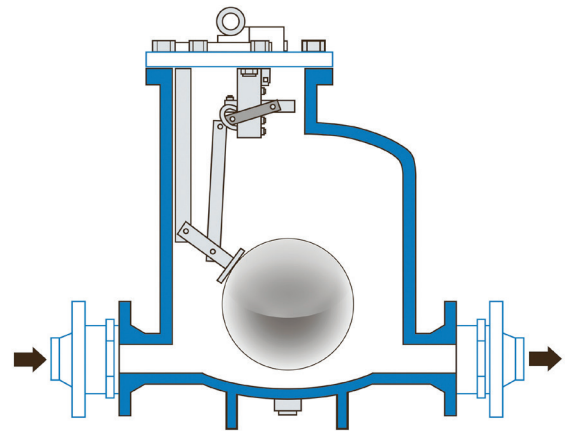

Application

- For lifting condensates, oils and other liquids to a higher level
- The float rises when condensate occurs
- At a certain level the vent valve closes and the valve opens for motive media that pushes the liquid to a higher level

Auslegungsmerkmale

- No cavitations
- Energy saving
- Very little steam consumption
- Extremely robust
- Can be delivered with a ready-to-operate station with collectors and fittings

Additional equipment

- Filling level gauge
- Stroke Counter

Application examples

- Returning the hot condensate into the vessel
- Under-pressure and vacuum systems
- Systems with high back pressures



Representatives and Distributors: Austria, Belgium, China, Croatia, Czech Republic, Denmark, Egypt, Finland, France, Great Britain, Hungary, India, Indonesia, Italy, Japan, Korea, Malaysia, New Zealand, Norway, Poland, Romania, Slovakia, South Africa, Spain, Sweden, Switzerland, Thailand, The Netherlands, Turkey, UAE, Ukraine, USA

Visit our website at www.rifox.de for more detailed information such as contact address of all sales partners, technical datasheets, operating manuals and graphic animations. For more information about our stock range please also visit our website www.rifoxglobal.com.

Contact



A Thermax Group Company

RIFOX - Hans Richter GmbH Spezialarmaturen
Bertha-von-Suttner-Str. 9
D-28207 Bremen

Phone: +49 (0)421 499 75 - 0
Fax: +49 (0)421 499 75 - 40

E-Mail: contact@rifox.de / sales@rifoxglobal.com
Internet: www.rifox.de / www.rifoxglobal.com